



Task 38 Solar Air-Conditioning and Refrigeration

D-A2:

Collection of selected systems schemes “Generic Systems”

**A technical report of subtask A (Pre-engineered systems
for residential and small commercial applications)**

Date: November 2009

By Michael Becker¹, Martin Helm¹ and Christian Schweigler¹

¹Institution	ZAE Bayern, Abtl.1: Technik für Energiesysteme und Erneuerbare Energien
Address	Walther-Meissner-Straße 6, D-85748 Garching
Phone	+49-89/329442-19
Fax	+49-89/329442-12
e-mail	schweigler@muc.zae-bayern.de

Contents

1. Scope.....	2
2. Basic system topology	2
3. Composition of generic systems	3
3.1 <i>Solar thermal sub-system.....</i>	<i>5</i>
3.2 <i>Heat rejection sub-system.....</i>	<i>8</i>
3.3 <i>Chilled water sub-system</i>	<i>10</i>
4. System control and hydraulics	12
4.1 <i>Solar thermal system.....</i>	<i>12</i>
4.2 <i>Capacity control.....</i>	<i>13</i>
4.3 <i>Auxiliary power demand.....</i>	<i>13</i>
4.4 <i>Solar Heating & Cooling.....</i>	<i>13</i>
5. Selection guide	15
6. System examples	18

1. Scope

For wide-spread application of solar cooling, compact systems shall be installed by professionals from the heating and plumbing sector without requiring a detailed planning procedure on a case-by-case basis. Thus along with the required equipment – i.e. thermally driven chiller, solar thermal system, and heat rejection device - well-proven system configurations have to be available for selecting an appropriate system concept with regard to the given specific requirements.

Work in subtask A, work package A2, focussed on providing “generic system schemes” representing standardized solar cooling systems and facilitating comparison of system concepts suggested by manufacturers and professionals in the field. Major objective is a favourable system operation in terms of optimised performance and availability

For this purpose a screening of the system technology applied in current solar cooling installations has been carried out. Apart from information furnished by component manufacturers and system providers, experience from pilot installations and recent academic work has been incorporated.

The survey is focussed on systems with the following characteristics:

- Pre-engineered systems, i.e. no case-specific planning is required
- Chilled water capacity < 20 kW
- Year-round operation for heating & cooling

This documentation of the state-of-the-art of small scale solar cooling systems is addressed to professionals, i.e. plant manufacturers, planners, and installers. It contributes to the background and common understanding of experts in the field and provides basic information required for implementation of the technology.

The generic solar cooling systems are composed of typical components and represent distinct system topologies applicable for various operating conditions and system boundaries. The given information is not product-specific or referring to a certain brand.

The main aspect is the hydraulic structure of the systems; in addition applicational aspects of the system components and control issues are discussed.

2. Basic system topology

Starting point for the definition of the system topology is the solar thermal system (Figure 1): The solar heat collected by the collector is transferred via a heat exchanger from the primary solar loop to the secondary loop. There, a heat store serves for balancing heat generation and heat consumption by the load. In times of insufficient solar gain a backup boiler is operated in order to provide additional heat input. The solar heating system may serve for both, space heating and tap water heating.

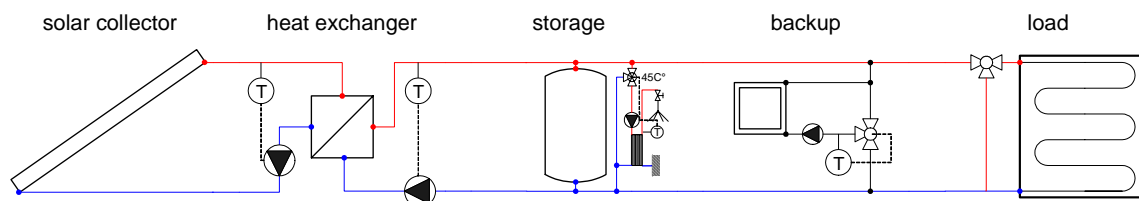

Figure 1: Solar thermal system, starting point for the definition of the solar cooling system.

In solar cooling systems a thermally driven sorption chiller is applied for the provision of useful cooling. In this case the heat generated by the solar thermal system serves as driving force for the thermally driven chiller. Taking into account the supply of useful cooling and the transfer of the chiller's reject heat to the ambient, a system with three sub-systems is formed, as shown in Figure 2:

- The solar thermal system provides heat to the desorber G of the chiller.
- Reject heat of condenser (C) and absorber or adsorber (A) are released via cooling water loop and cooling tower.
- Useful cooling is provided by the evaporator (E) and supplied to the consumer via the chilled water loop.

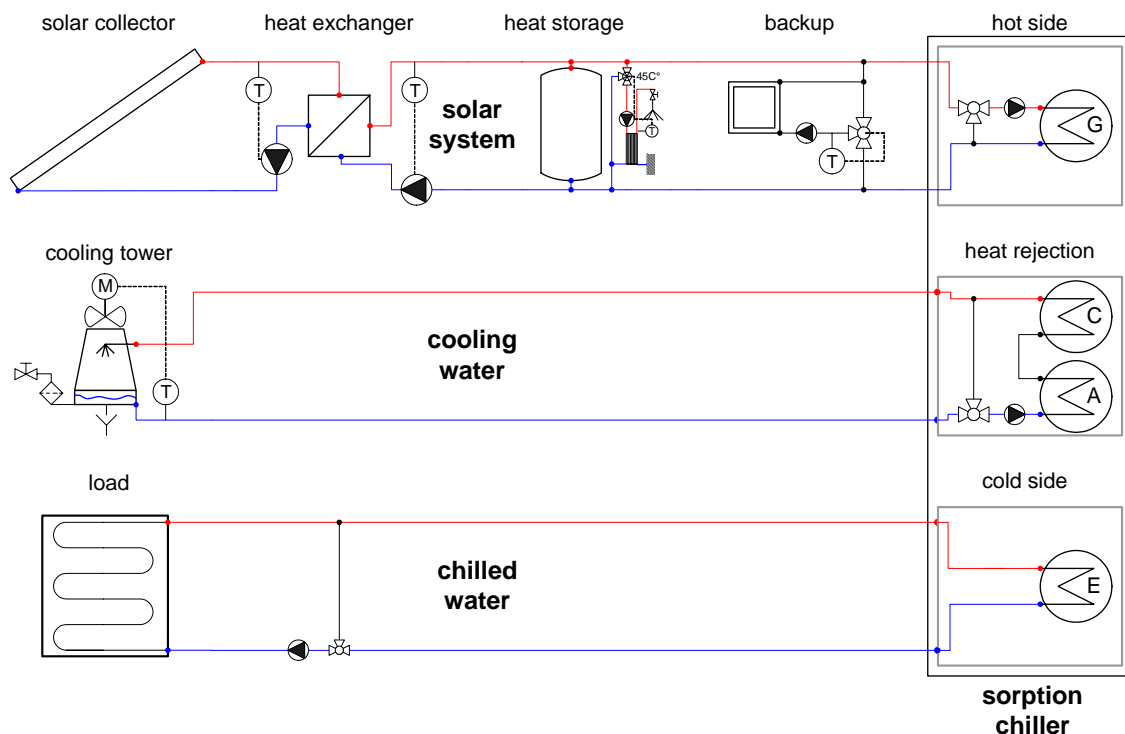

Figure 2: Basic solar cooling system: Thermally driven chiller coupled to solar thermal system, cooling water loop, and chilled water loop.

3. Composition of generic systems

In order to cope with different ambient conditions, specific demand characteristics of heating and cooling, and the room-side appliances for heating and cooling, in real applications a variety of technical options is available for all three sub-systems.

The different options are presented on basis of a standardized system topology according to the basic structure of the "generic system" discussed above as shown in Figure 3. For each sub-system a structural template has been defined containing placeholders for the integration of additional components.

In detail, the following options are to be specified in the three sub-systems.

Solar sub-system:

- Solar collector

- Heat exchanger
- Heat storage
- Backup-heater

Heat rejection sub-system:

- Main cooler
- Auxiliary cooler
- Heat exchangers for separation of primary and secondary cooling loop

Chilled water sub-system:

- Load: Room-side cooling appliance
- Distribution of chilled water to the cooling appliances
- Cold (chilled water) storage
- Backup chiller

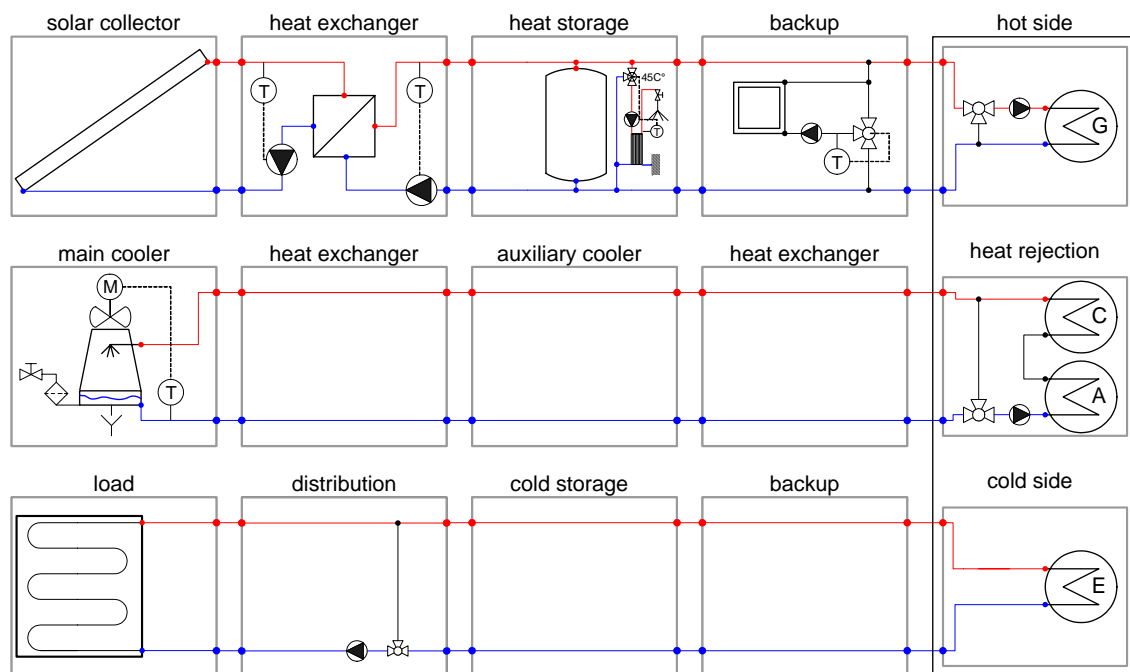

Figure 3: Generic system: standardized system topology with placeholders for the integration of optional system components.

In the following sections, typical constellations and alternative components for the three sub-cycles are presented. For each placeholder all relevant options together with a characterisation of technical and operational aspects are given.

3.1 Solar thermal sub-system

All types of **solar collectors** – i.e. flat plate collectors, vacuum tube collectors and concentrating collectors – are applicable. Vacuum tubes and concentrating collectors often exhibit higher collector efficiencies at elevated temperatures of the solar loop. Thus higher availability of the system is accomplished during times of limited solar irradiation.

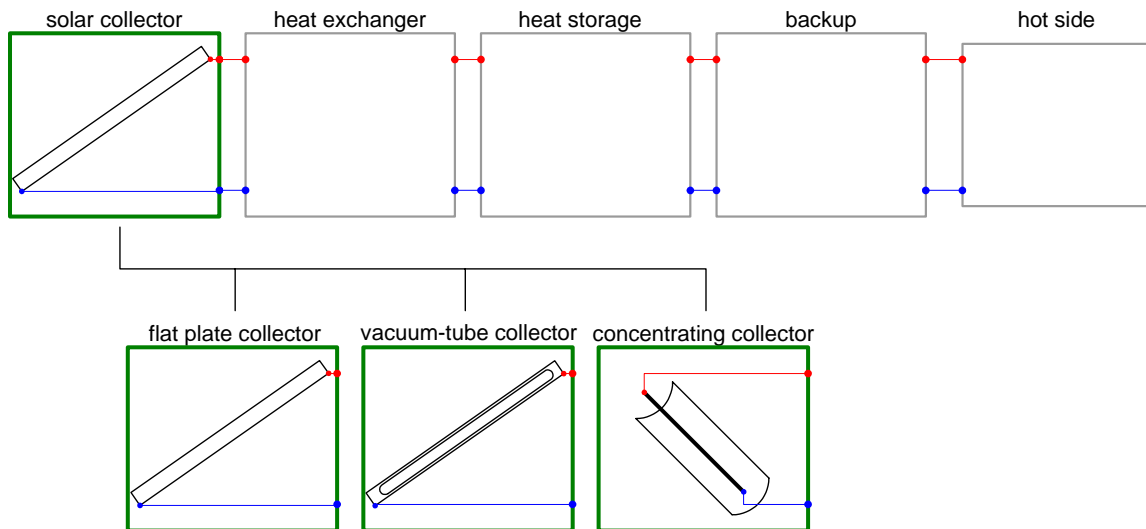

Figure 4: Solar sub-system: options for the solar collector

In the solar thermal system a **heat exchanger** can be integrated for separation of primary and secondary loop. In conventional systems a water/glycol mixture together with a separating heat exchanger is used, assuring trouble-free operation throughout the year at the expense of a reduction of the temperature level in the secondary loop due to the heat transfer in the heat exchanger. In order to avoid the reduction of the temperature level a “direct” utilization of the solar heat may be applied. In this case either freezing of the heat carrier water has to be avoided by means of heat input from the backup-heater or an electrical heater, or a drain-back concept has to be chosen. When the later is applied, the collector loop is filled by the circulating pump only when substantial solar contribution for

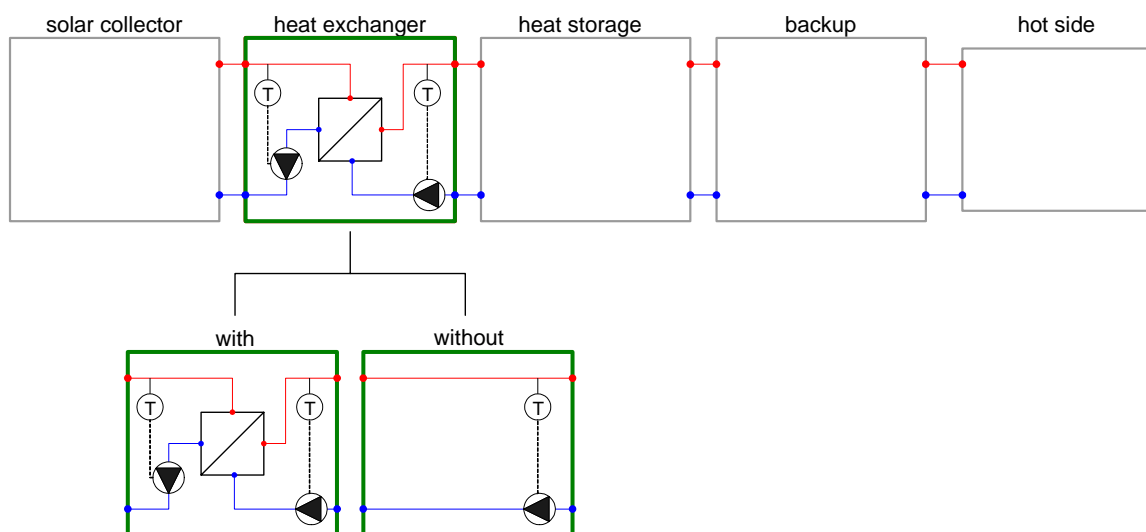

Figure 5: Solar sub-system: heat exchanger for separation of primary and secondary solar loop.

operation of the system in heating or cooling mode is to be expected. A third option would be to drive the chiller directly with the water-glycol mixture, taking into account changing heat transfer rates in the desorber of the chiller.

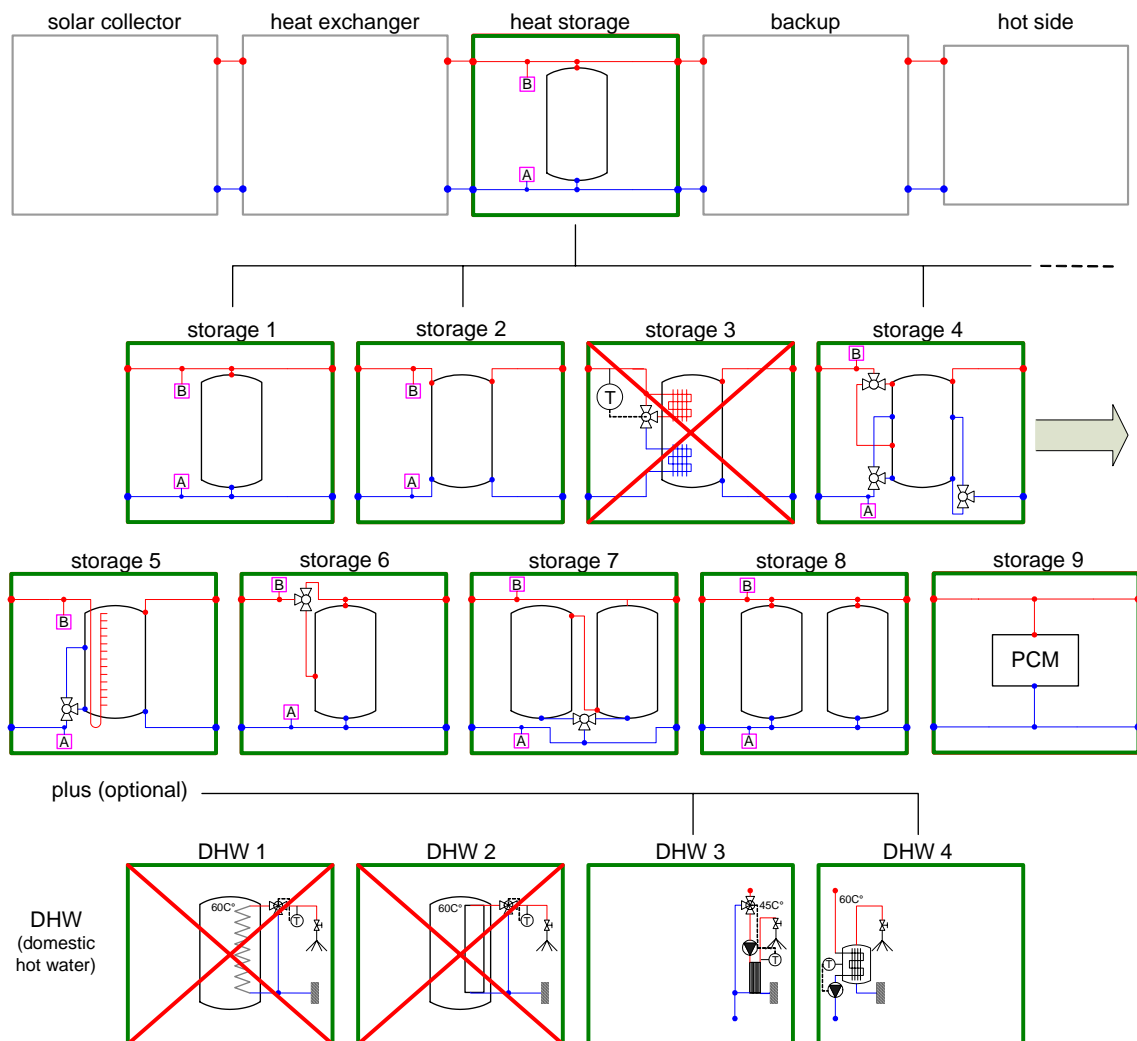

Figure 6: Solar sub-system: options for the heat storage and domestic hot water preparation.

In order to balance solar gain and the profile of the heat consumption, solar thermal systems comprise a **hot water heat storage**. For operation of the thermally driven chiller solar heat at a sufficiently high temperature level is required and any devaluation (cooling by mixing or heat exchange) of the solar heat should be avoided. Thus a direct integration of the storage without heat exchanger is favourable, eliminating a temperature drop during charging and discharging of the store. Therefore, option "storage 3" in Figure 6 is not suitable for solar cooling. In addition the active storage volume should be variable in order to achieve a quick increase of the solar loop temperature for minimum delay between onset of solar irradiation and start of the production of chilled water by the chiller. For this purpose a direct link between solar heat generation and supply of driving heat to the chiller can be chosen ("storage 1, 6, 7, and 8"). For these cases it must be assured that the store still properly serves as a hydraulic switch between heat generation and load. Therefore only minimum pressure drop between supply and return line of the solar thermal system across the store is allowed in order to avoid parasitic flows. Parasitic flows might occur when only the solar collector is charging the store (parasitic flow may occur at the auxiliary heater or the desorber) or when the store is only discharged (parasitic flow

may occur on the collector side). In addition, the return line feeding cold water from the storage to the collector inlet can be switched to a lower outlet port of the store when the top layer of the storage has reached the desired driving temperature for the operation of the chiller ("storage 4 and 5"). By that means a reduced thermal inertia of the solar cooling system is achieved with shorter start-up time in the morning. In larger systems two storage tanks connected in series to the solar heat supply can be used ("storage 7"). In this configuration charging of the second store is started only when the first store has been heated completely. "Storage 8" with two parallel storage tanks may serve for reduced flow speed in the storage facilitating a stratified loading with optimum temperature in the top layer of the storage. For the same purpose storage tanks with a distributed feeding system for stratified charging can be applied ("storage 5"). Latent heat stores ("storage 9") offer the advantage of high thermal capacity in a limited temperature interval. Accordingly, a substantial reduction of the thermal inertia of the system could be achieved; yet these systems are still under development.

Apart from space heating and the supply of driving heat for the sorption chiller, solar heat serves for the generation of domestic hot water. In solar combisystems without cooling function, tap water is either heated inside the main heat store by means of an integrated heat exchanger ("DHW 1") or a tank-in-tank system ("DHW 2") or an external flat plate heat exchanger ("DHW 3") or a separate domestic hot water tank ("DHW 4") is used. For the first two options with tap water preparation inside the main heat store, most manufacturers recommend to limit the tank temperature to about 60°C in order to avoid scaling and calcification in the tap water system. This limitation is not compatible with the requirements for the operation of the thermally driven chiller which is operated with about 60 to 90°C hot water supply temperature. Consequently, a solution with external DHW preparation ("DHW 3" or "DHW 4") is more favourable.

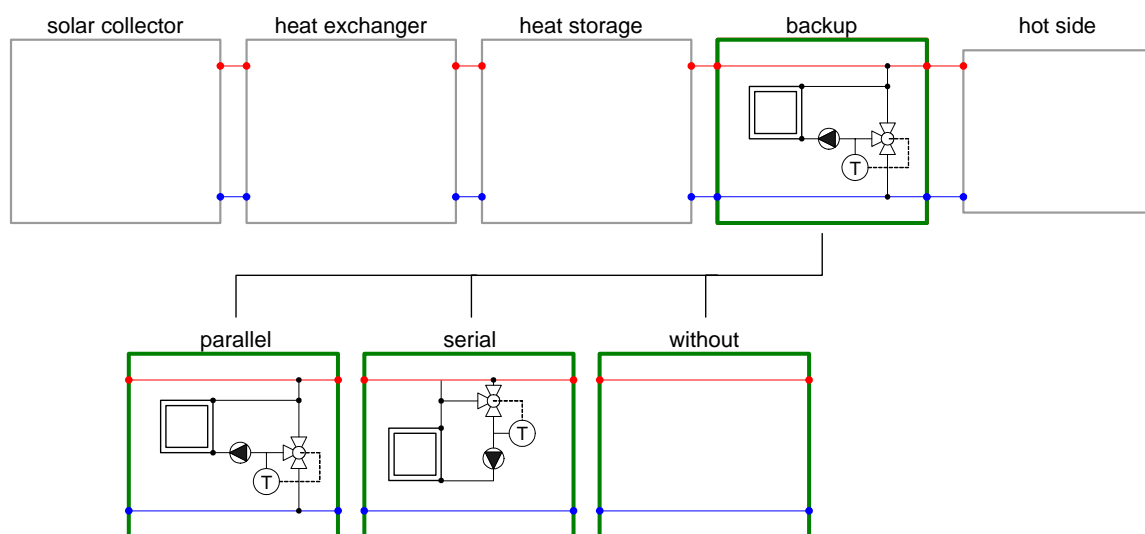

Figure 7: Solar sub-system: options for the integration of the backup-heater.

For supplementing the solar collector system in conventional solar heating systems a **backup-heater** is applied for continuous heat supply during periods of insufficient solar gain. Analogously the backup heater can provide driving heat for the sorption chiller, guaranteeing unrestricted availability of the solar cooling system independently from the output of the solar collector system. Yet, with regard to the required primary energy input only marginal contribution of the backup heater should be allowed. When large amounts of cooling shall be provided without solar heat input, e.g. during the late evening or during night time, a backup chiller integrated into the chilled water sub-system is a promising alternative in terms of primary energy utilization. Then for the solar sub-system no backup

heater is required as long as the system serves for solar cooling only. In Figure 7 two options for the integration of the backup-heater are shown. The backup heater is either placed in parallel to the heat storage tank (see “parallel” in Figure 7) or adds heat to the hot water supply line approaching the desorber of the thermally driven chiller (“serial”). Apart from direct integration into the hot water loop driving the chiller, the backup-heater can also provide heat to the heat storage tank. From there the heat can be distributed to all heat consumers. These details are not shown in the graph.

3.2 Heat rejection sub-system

In the heat rejection sub-system different cooling tower types are applicable as **main coolers** (see Fehler! Verweisquelle konnte nicht gefunden werden.). For given ambient conditions lowest cooling water temperatures are accomplished by utilizing an open wet cooling tower. A closed cooling water loop allows for less maintenance effort. In this case either a closed wet cooling tower or a dry air cooler may be chosen. The dry air cooler eliminates the formation of fog and legionella bacteria growth at the expense of an increase of the cooling water temperature compared to the wet cooling tower options. Apart from the heat transfer to the ambient air alternative heat sinks may be used in specific situations: A swimming pool offers both a reasonably low temperature level and the option of re-utilizing the reject heat of the sorption cooling process. As an alternative, geothermal systems may be used for dumping the reject heat: Options are ground heat exchangers, boreholes or ground water wells. Heat transfer to these geothermal installations during cooling mode of the system may have a positive impact on the system performance during the inverse operating mode, i.e. during heating operation with the thermally driven chiller operating in heat pump mode. When reject heat is stored underground during the cooling season the average annual ground temperature stabilizes at a higher value facilitating the extraction of ambient heat during the heating season.

The heat rejection via the main cooler may be assisted by an **auxiliary cooler** (see Figure 9), allowing for re-utilization of the reject heat for heating of domestic hot water (“DHW

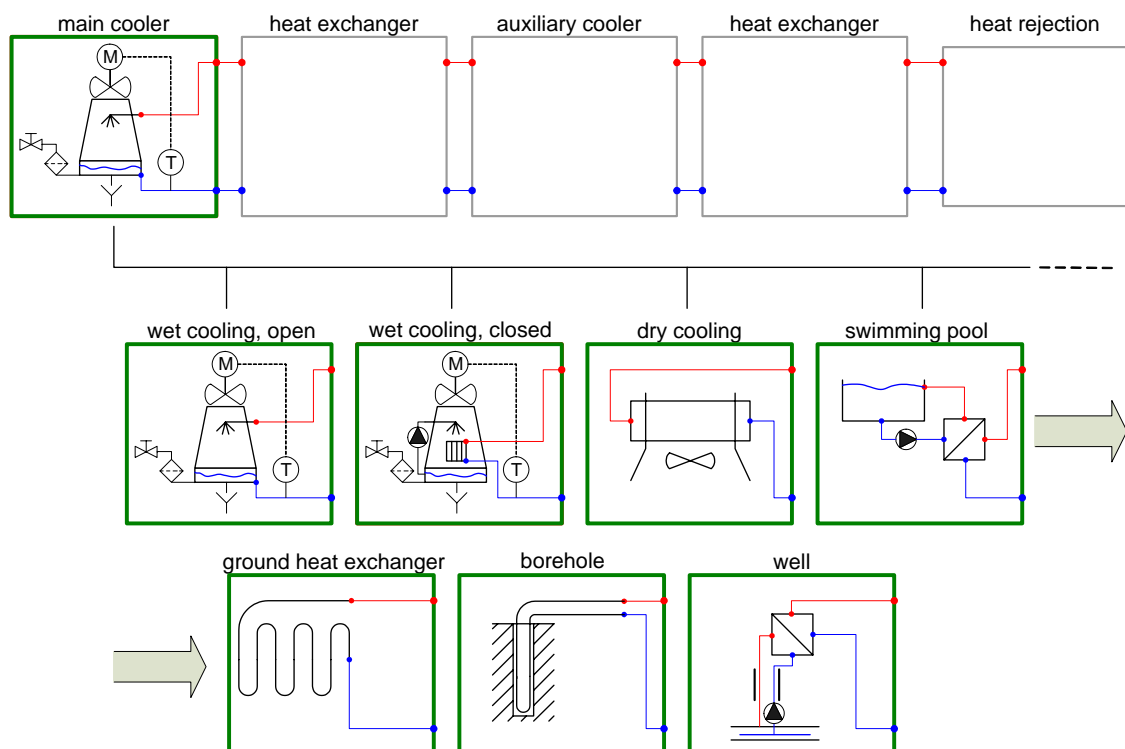

Figure 8: Heat rejection sub-system: open and closed wet and dry cooling towers and alternative heat sinks.

preheating”) or a swimming pool. Other alternatives are the heat transfer to the exhaust air of an air-handling unit (“AHU”) or a latent heat store (“PCM storage”). The latter two options may offer reduced effort for the transfer of the reject heat to ambient in terms of parasitic energy consumption or operating cost. While the main cooler is continuously available, the capacity and availability of the auxiliary cooler may be limited. Therefore, the auxiliary coolers are installed in the cooling water line leaving the sorption chiller or in parallel to the main cooler. In any case the main cooler assures the desired temperature drop of the cooling water, either by adjusting the flow rates through main cooler and auxiliary cooler or by setting the capacity of the main cooler accordingly.

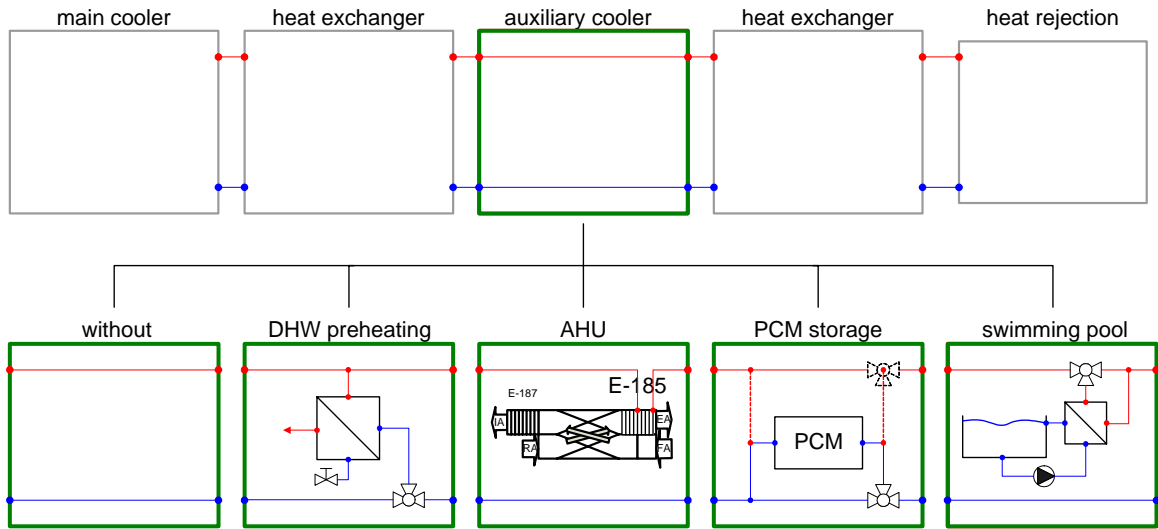

Figure 9: Heat rejection sub-system: auxiliary coolers.

In conventional cooling installations open wet cooling towers are directly coupled to absorber and condenser of the chiller. In order to avoid fouling of the cooling water system due to intake of any pollutants from the open cooling tower, a **heat exchanger** may be installed. Although the thermally driven chiller itself may to some extent tolerate this fouling effect, a heat exchanger is required when additional components like an auxiliary cooler are integrated into the cooling water system. Under certain circumstances a heat

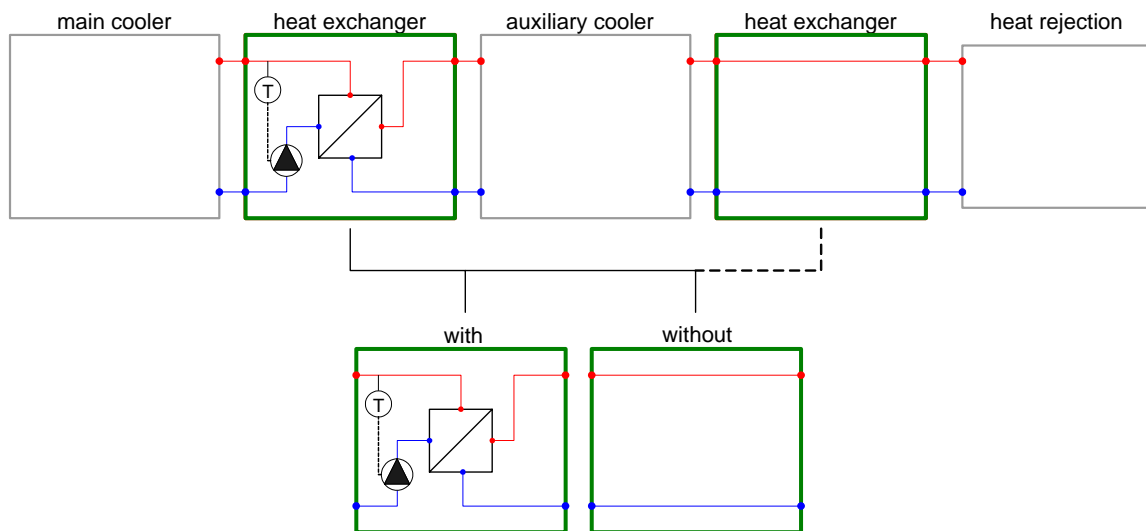

Figure 10: Heat rejection sub-system: optional heat exchangers for separation of thermally driven chiller, auxiliary cooler and main cooler.

exchanger has to be placed between auxiliary heater and chiller.

3.3 Chilled water sub-system

For the transfer of the cooling effect different **room-side installations** are available (see Figure 11). For cooling and dehumidification of the room air either air-handling units (“AHU”) or fan coils may be chosen. For dehumidification chilled water temperatures below the dew point of the supply air are required. If only sensible cooling is desired elevated chilled water temperature is sufficient for the operation of radiative cooling surfaces (“radiative heating/cooling”). The same installation can be used for radiative heating during the heating season.

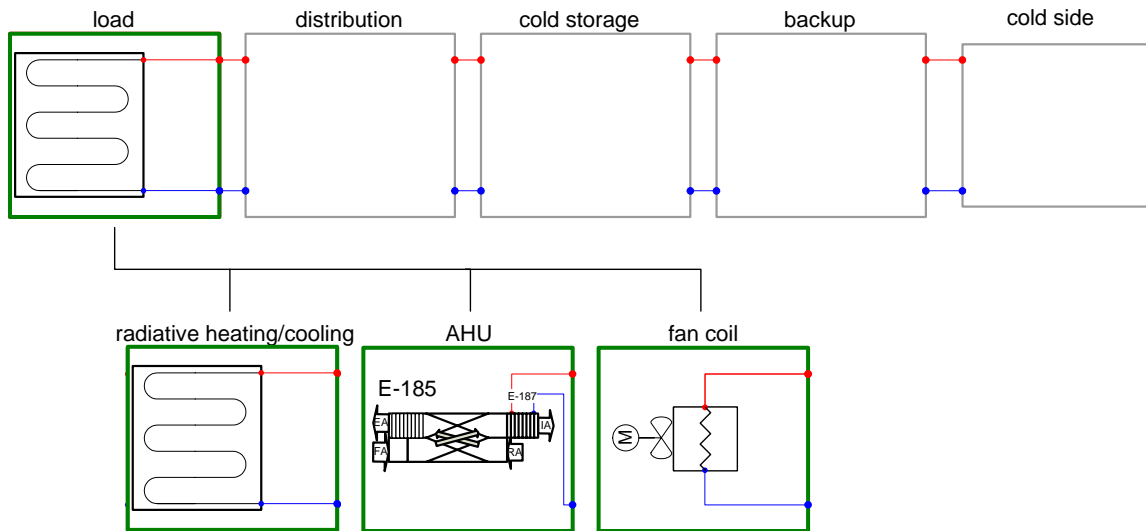

Figure 11: Chilled water sub-system: Room-side installations for the transfer of the cooling effect.

For the **distribution of the chilled water** to the above cooling appliances different hydraulic configurations are feasible (Figure 12): In general a mixing valve between chilled water supply and return line is applied for adjusting the operating temperature of the room-side appliance (“single”). In distributed systems coolers of the same type are installed in parallel in order to assure equal operating conditions. In the graphs a second

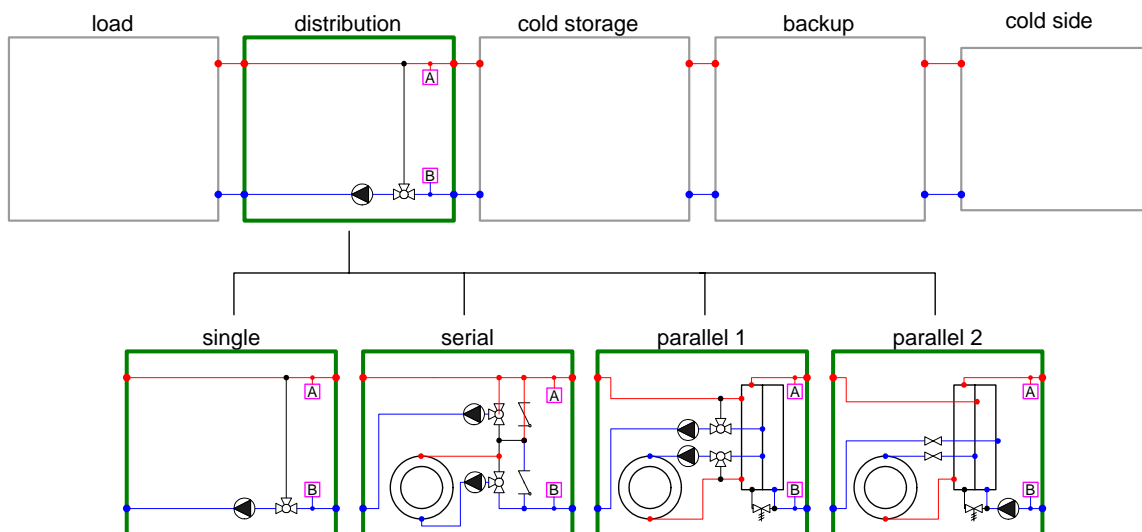

Figure 12: Chilled water sub-system: Options for the distribution of the chilled water.

load is depicted by two concentric circles. In the configuration “parallel 1” for each loop a pump together with a mixing valve is installed. In configuration “parallel 2” the main chilled water pump at the inlet port of the distributor serves for circulation of the chilled water throughout the whole chilled water system. Temperature adjustment is accomplished by means of flow control by two-way valves in each sub-loop. If coolers of different types shall be operated with different chilled water supply temperature a serial configuration (“serial”) allows for stepwise utilization of the cooling effect. As a consequence, the serial concept allows for higher chilled water return temperature and enhanced performance and capacity of the chiller.

In the case of larger fluctuations of the cooling demand (which results in fluctuations of the volume flow between distribution and storage) a **cold storage** serves for levelling the chilled water consumption by decoupling the volume flow of the load and the chiller, and facilitates stable operation of the thermally driven chiller (Figure 13). Predominantly chilled water is used as storage medium. The storage is either directly loaded (“cold storage 1” and “2”) or an internal heat exchanger (“cold storage 3”) serves for the separation of the primary and secondary cooling loop. In analogy to the solar sub-system, the configuration “storage 1” with direct link from chilled water production to the load allows for bypassing the cold storage. Consequently, the chilled water flow transiting the storage vessel is reduced and mixing of the storage volume is avoided. Again hydraulic integration with minimum pressure drop is essential for avoiding parasitic flows in the chilled water system. The configuration “storage 3” induces a temperature loss between primary and secondary chilled water loop and is therefore not recommended. Yet, a separation of the hydraulic loops by a heat exchanger may be required if an ice storage shall be applied. In the future the use of other phase change materials as storage medium or PCM slurries may gain increasing importance. As a result due to the latent heat effect a reduction of the storage volume in comparison to a chilled water tank is accomplished.

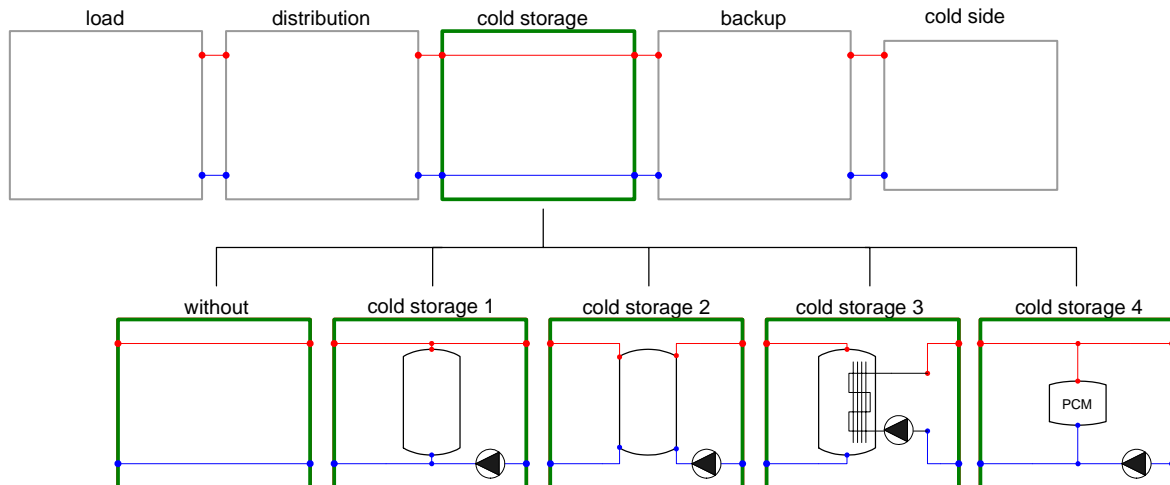

Figure 13: Chilled water sub-system: Chilled water storage and latent cold storage (PCM, phase change material).

If a reliable chilled water supply has to be guaranteed – independently from the availability of the solar driving heat – a **backup cooling source** may be provided. For this purpose a compression chiller may be installed in the chilled water supply line. If the thermally driven chiller does not provide sufficient cooling capacity, the mechanical chiller is controlled in order to reach the desired chilled water supply temperature. As an alternative a ground water well or any other geothermal installation, e.g. a borehole or a ground heat exchanger, can serve as backup cooler. During the winter the ground water well may be used as geothermal heat source for the system operating in heat pump mode.

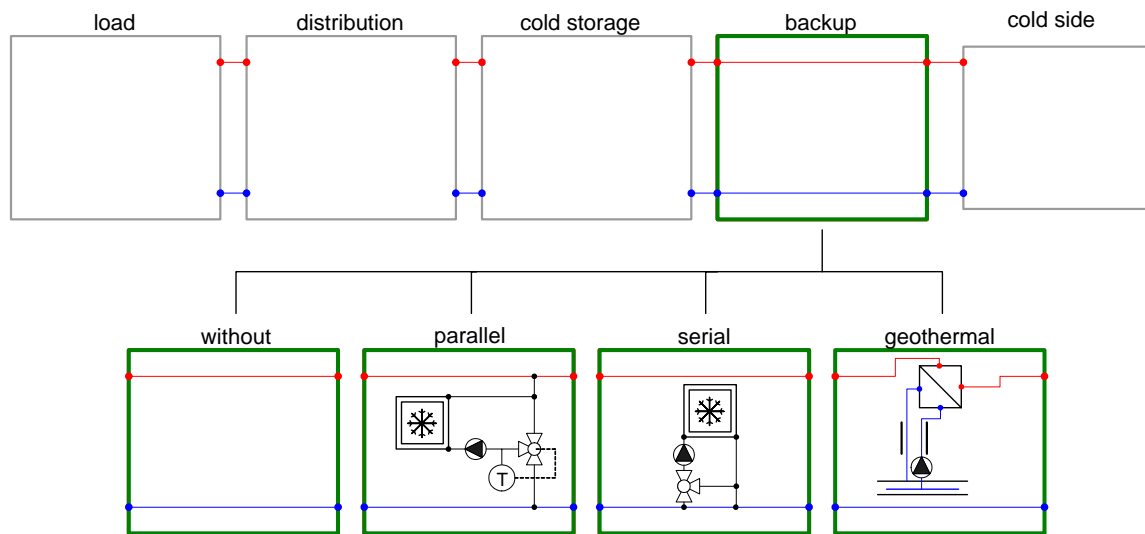

Figure 14: Chilled water sub-system: Integration of a compression chiller or a ground water well as backup cooling source.

4. System control and hydraulics

4.1 Solar thermal system

The thermo-physical properties of the sorbent used in the thermally driven chiller set the required temperature level of the driving heat which is applied to regenerate the sorbent in the desorber of the chiller. Consequently, when the solar heat from the collector system serves as driving heat for the chiller the solar collector loop is to be operated with limited temperature lift and with high volume flow of the heat carrier. Thus, in low-flow collector installations, which are needed for combisystems (combined space heating and domestic hot water production), a change of the pump setting together with a change of the hydraulic configuration may be required for the cooling season to avoid extremely high collector temperatures resulting in inefficient collector performance with the risk of stagnation of parts of the collector circuit due to boiling of the water-glycol mixture.

In solar heating mode, the solar thermal system may operate at moderate temperatures providing heat input to a low temperature heating system or serving for preheating of a tap water flow. Given a favourable hydraulic integration the system reaches an operational state after a short start-up phase. During operation surplus solar heat results in a gradual increase of the system temperature with a heat storage effect within a rather large temperature interval. As stated above in solar cooling mode the solar heat has to exceed a certain minimum temperature level required to drive the sorption chiller. Consequently, after start of the solar thermal system with incipient solar radiation in the morning hours a substantial amount of heat has to be collected in order to reach the required operating temperature. To achieve a quick response of the system with only short delay between the start of the solar thermal system and the operation of the chiller the thermal inertia of the system has to be limited or stratifiers for charging the heat store in combination with a matched flow system have to be applied. For this purpose the volume of the heat storage, its modular design and hydraulic integration, the loading strategy of the heat storage, and the collector hydraulics and control have to be chosen accordingly, as discussed in section 3.1.

4.2 Capacity control

For the purpose of capacity control the chilled water supply temperature serves as the controlled variable. Conventionally, the hot water supply temperature represents the manipulated variable. Actuating device is a three way mixing valve at the inlet port of the desorber of the thermally driven chiller. For reducing the chilled water capacity of the chiller the entering hot water temperature is reduced by recirculating cooled hot water leaving the desorber back to the desorber inlet. As an alternative the chilled water capacity can be controlled by manipulating the hot water flow through the desorber by either a speed control of the hot water pump or by means of a two-way regulating valve.

According to the state-of-the art, cooling systems operate with fixed chilled water supply temperature. For standard comfort air-conditioning the chilled water supply temperature is set to 6°C or 45°F with a supply-return span of 6 K or 10°F. In part load operation with fixed chilled water supply temperature the return temperature drops accordingly. Deviating from this established convention, i.e. operation with fixed chilled water supply temperature, a positive effect on the performance of the solar cooling system would be achieved by controlling the chilled water return temperature to a fixed value. Consequently, the thermally driven chiller would be operated with increasing chilled water supply temperature during part load operation. Thus a lower driving hot water temperature would be sufficient resulting in a higher contribution of the solar collector and reduced need for backup operation of the boiler or the compression chiller, respectively.

4.3 Auxiliary power demand

With regard to the desired primary energy saving effect, the operation of all system components has to be optimized. In order to reduce the pumping energy demand highly efficient pumps should be used together with a reasonable control strategy avoiding circulation of the solar thermal system with only marginal solar gain.

When a dry air-cooler is applied the blower fan of the heat rejection system significantly contributes to the overall electric power demand. For this case a change of the system's capacity control promises increased system efficiency: Given sufficient solar driving heat, in case of decreasing chilled water demand the transfer characteristic of the heat rejection system can be reduced by manipulating the fan speed of the dry air-cooler. As a result the chilled water capacity is reduced at constant operation of the driving solar thermal system. In a second step the heat input into the desorber may be adjusted for matching the chilled water demand if required.

4.4 Solar Heating & Cooling

As stated earlier, the topology of the solar cooling system incorporates the solar collector system as driving heat source. With regard to the year-round operation the system has to serve for both heating and cooling. For this purpose the hydraulic system has to be prepared for a switch from solar cooling to solar heating. An example is shown in . Ideally the room-side appliances, e.g. radiative heating/cooling surfaces, are designed for both modes of operation. Heat for space heating and tap water preparation is provided by the solar collector system. Backup heating is accomplished by a backup heater.

Apart from solar heating supported by a backup heater the system may be operated in heat pump mode with the thermally driven chiller serving as a heat pump for the provision of low-grade heat for space heating (). A geothermal installation, e.g. a ground water well operating as backup cooler in cooling mode, can be utilized as heat source linked to the evaporator of the heat pump. During winter, only marginal contributions of the solar collector system are to be expected. Thus driving heat for the sorption heat pump is predominantly provided by the backup heater. Useful heat is extracted at absorber or adsorber and condenser of the sorption cycle and is distributed to the heating appliances.

Peak load heating demand can be covered by additional heat input from the high temperature sub-system comprising the solar collectors and the backup heater.

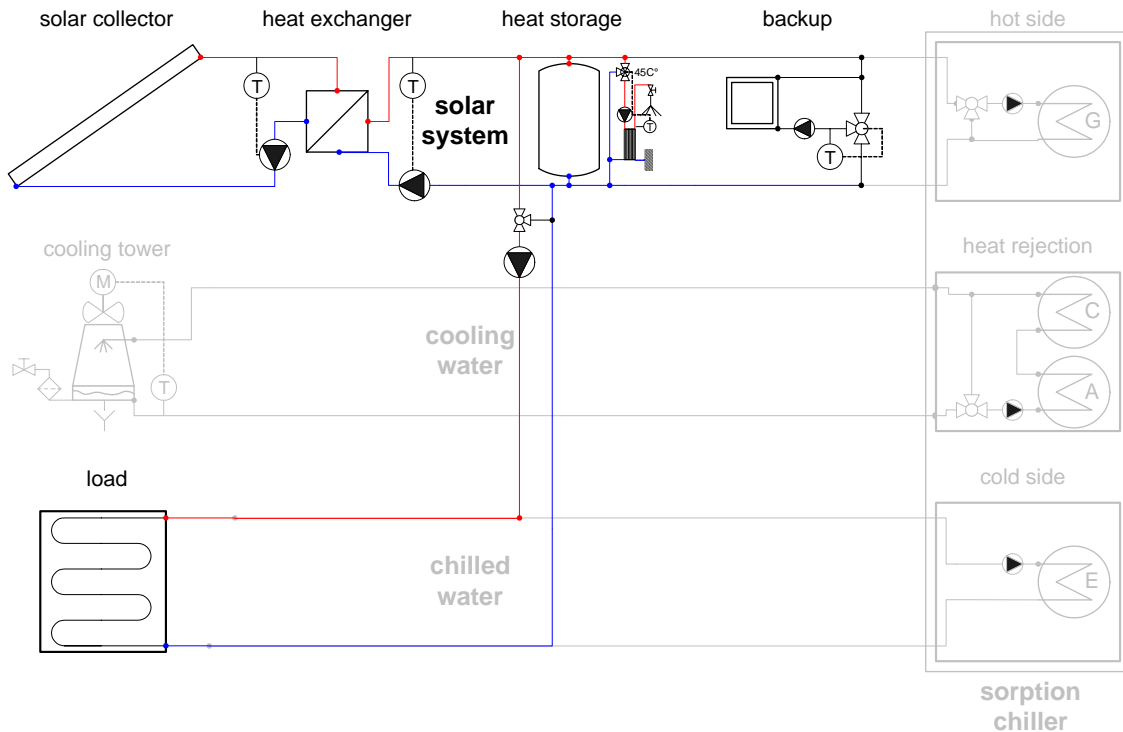

Figure 15: Operation of the solar heating and cooling system in solar heating mode.

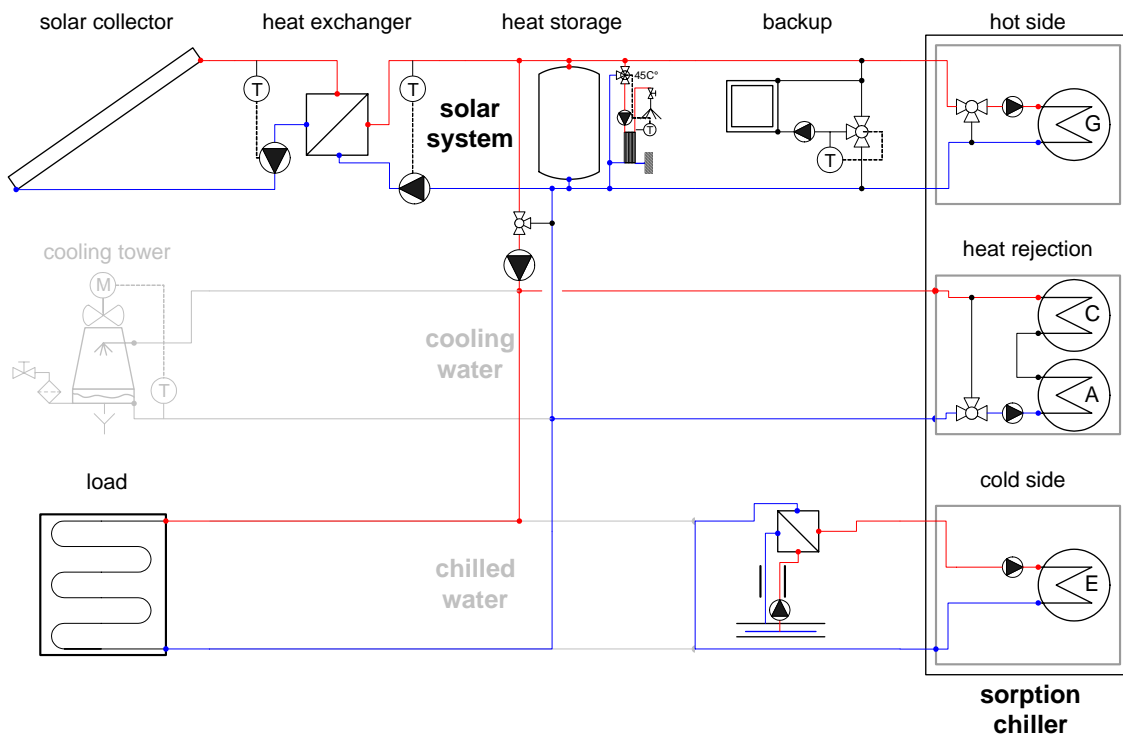

Figure 16: Operation of the solar heating and cooling system in heat pump mode.

5. Selection guide

In the following tables a comparative characterization is given, summarizing the technical discussion in the previous sections.

	function or main characteristic	additional information
solar thermal sub-system		
solar collector	accumulation of solar heat	
flat plate collector	cost efficient	robust, reliable
vacuum-tube collector	low thermal losses	high collector efficiency, low collector area required
concentrating collector	optimum efficiency for direct radiation	high collector efficiency, suitable for double-effect chiller
heat exchanger	separation of hydraulic loops	
with	anti-freeze liquid in solar loop	negative impact on thermal performance due to driving temperature difference
without	measures for freeze-protection required	pure water as solar heat carrier or drain back system or water-glycol mixture directly supplied to sorption chiller
heat storage	storage of surplus solar heat	
storage 1	direct link between collector and heat consumer	simple construction, reduced flow facilitates stratification
storage 2	no bypass, all hot water flows pass through storage	simple construction, decouples volume flows, no parasitic flows
storage 3	not applicable	
storage 4	charging and discharging section-wise	switching valves for selection of heat storage section
storage 5	exact stratification	gravity loading system
storage 6	charging and discharging section-wise	switching valve for selection of heat storage section
storage 7	charging and discharging section-wise	switching valve for activation of additional storage volume
storage 8	enhanced storage capacity	adjustment of storage volume by supplementary installation of storage tanks
storage 9	latent heat storage: maximum storage density	operation with characteristic temperatures for loading and unloading
DHW (domestic hot water)	tap water heating	
DHW 1	not applicable	
DHW 2	not applicable	
DHW 3	external heat exchanger	instantaneous tap water preparation
DHW 4	external tap water storage	storage covers load peaks
backup	auxiliary heat source	
parallel	hot water boiler	parallel installation, loading of heat storage possible
serial	hot water boiler	serial installation, boosts hot water supply temperature, no loading of heat storage
without		

	function or main characteristic	additional information
heat rejection sub-system		
main cooler	guarantees transfer of reject heat under all ambient conditions	
wet cooling open	best cooling capability, theoretic limit: wet bulb temperature	low cooling water temperature, consequently low driving hot water temperature for sorption chiller. water make-up required, risk of legionella infection and fog formation.
wet cooling closed	good cooling capability, increased cooling water temperature due to additional heat transfer	water make-up required, risk of legionella infection and fog formation.
dry cooling	reliable, trouble-free operation. only sensible cooling: elevated cooling water temperature	requires higher driving hot water temperature for sorption chiller. For water/LiBr chiller not applicable in hot climates.
swimming pool	re-utilization of the reject heat	increasing cooling water temperature due to limited storage capacity
ground heat exchanger	heat transfer to surface ground layer	high installation effort, low parasitic power demand
borehole	heat transfer to deep ground	high installation effort, low parasitic power demand
well	heat transfer to ground water	high installation effort, low parasitic power demand
heat exchanger	separation of hydraulic loops	
with	avoids intake of pollutants from open cooling loop	
without		
auxiliary cooler	re-utilization of the reject heat	
without		
DHW preheating	tap water heating	substitutes fresh heat (solar heat or fossil fuel)
AHU	heat transfer to exhaust air of AHU	replaces dry air-cooler
latent heat storage (PCM)	storage of waste heat	facilitates application of dry air-cooler even in hot climates
swimming pool	heating of pool water via heat exchanger	substitutes fresh heat (solar heat or fossil fuel)
heat exchanger	separation of hydraulic loops	
with	separation from water/glycol loop	
without		

	function or main characteristic	additional information
chilled water sub-system		
load		
radiative heating/cooling	only sensible cooling, no dehumidification, heating in winter	moderate temperature level for heating and cooling , chilled water temperature above dewpoint
AHU	heating, cooling and dehumidification	low chilled water temperature required for dehumidification
fan coil	heating, cooling and dehumidification	condensate handling required for dehumidification
distribution		
single	single cooling appliance (see options "load")	pump and mixing valve for control of entering chilled water temperature. No chilled water pump at chiller port required.
serial	cascade of cooling appliances operating at different temperature levels	chilled water return flow from first cooler is used in following cooler, supply temperatures are controlled individually
parallel 1	parallel installation of cooling appliances	pump and mixing valve for individual setting of supply temperatures, chilled water supply to distributor by chilled water pump at chiller port
parallel 2	parallel installation of cooling appliances	pump and flow control for individual setting of supply temperatures, chilled water supply to distributor by chilled water pump at chiller port
cold storage		
without		
buffer 1	direct link between chilled water generation and load	simple construction, reduced flow facilitates stratification
buffer 2	no bypass, all chilled water flows pass through storage	simple construction, decouples volume flows, no parasitic flows
buffer 3	storage loaded by internal heat exchanger, ice storage	chiller operates at lower temperature, negative impact on chiller efficiency and/or higher driving temperature required
buffer 4	latent cold storage	hydraulic concept to be defined
backup		
without		
parallel	compression chiller, parallel integration	split flow to different chillers, sorption cooling covers base load only
serial	compression chiller, serial integration	sorption chiller designed for full load, backup chiller provides final cooling when solar driving heat not sufficient
geothermal	free cooling by heat transfer to geothermal source	optimum energy saving

6. System examples

The following figures show a selection of system configurations and their representation on basis of the “generic system” scheme discussed in this report. The first three examples have been suggested by manufacturers. The last two examples represent pilot installations.

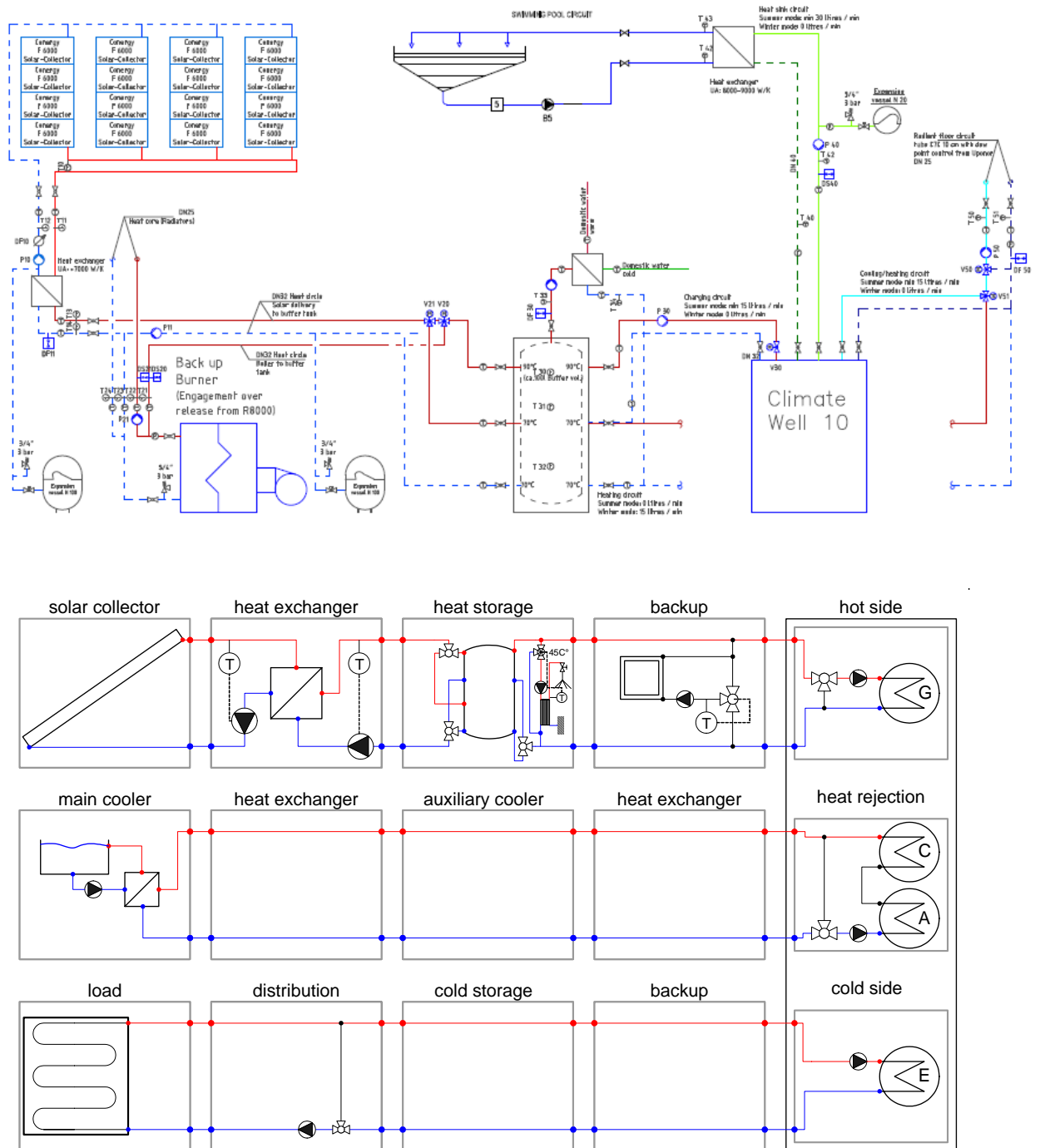

Figure 17: Solar heating and cooling system, Example 1 (source: Climatewell).

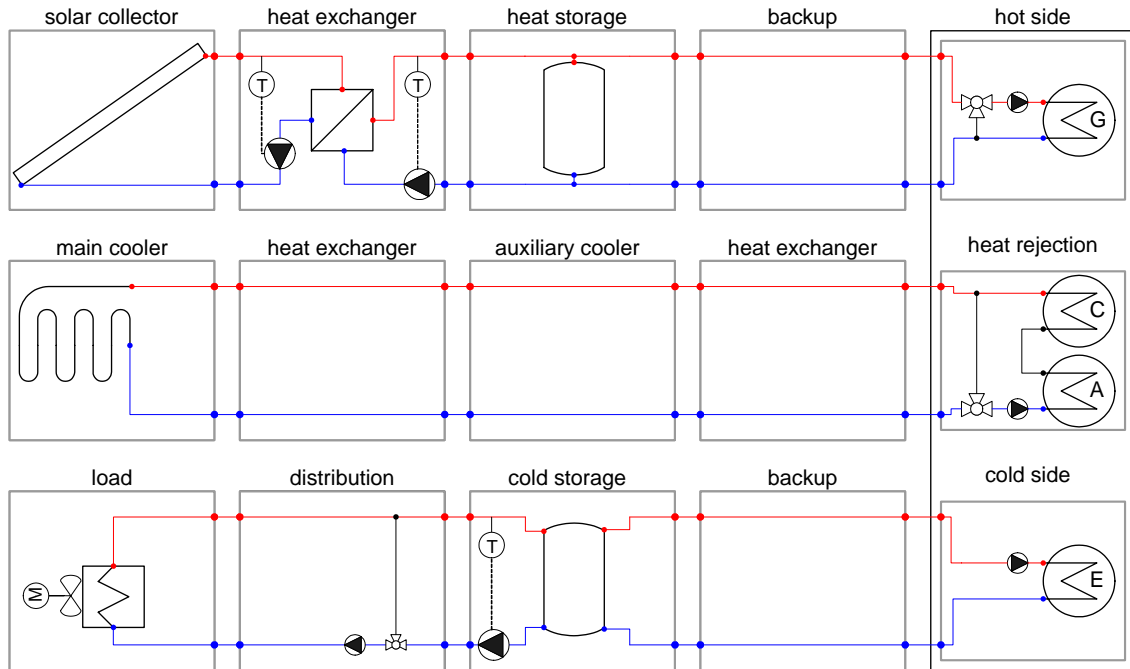
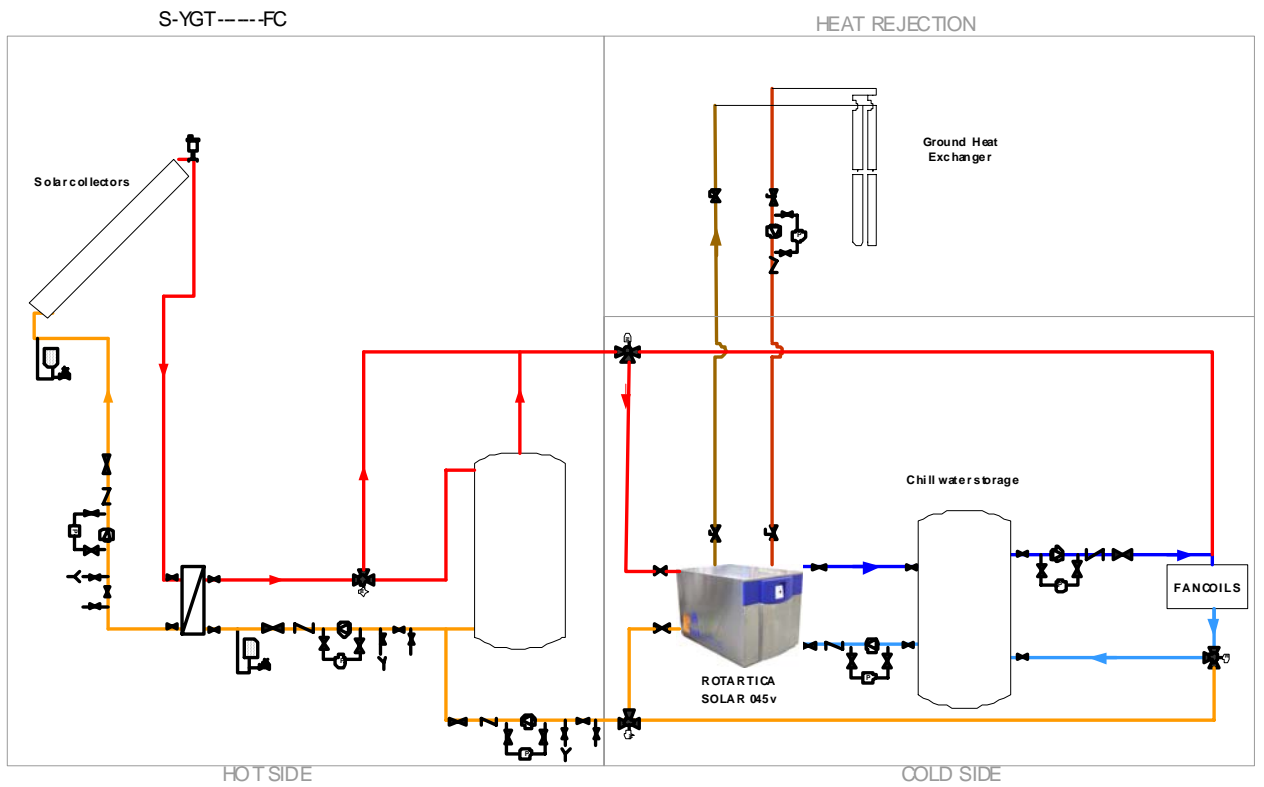

Figure 18: Solar heating and cooling system, Example 2 (source: Rotartica).

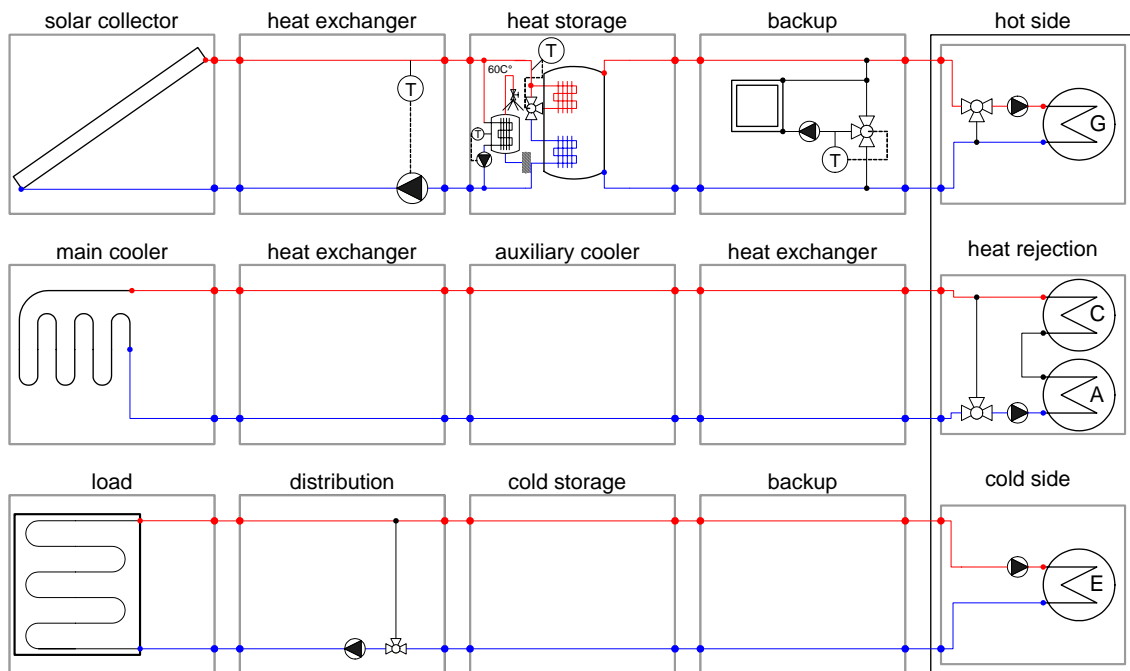
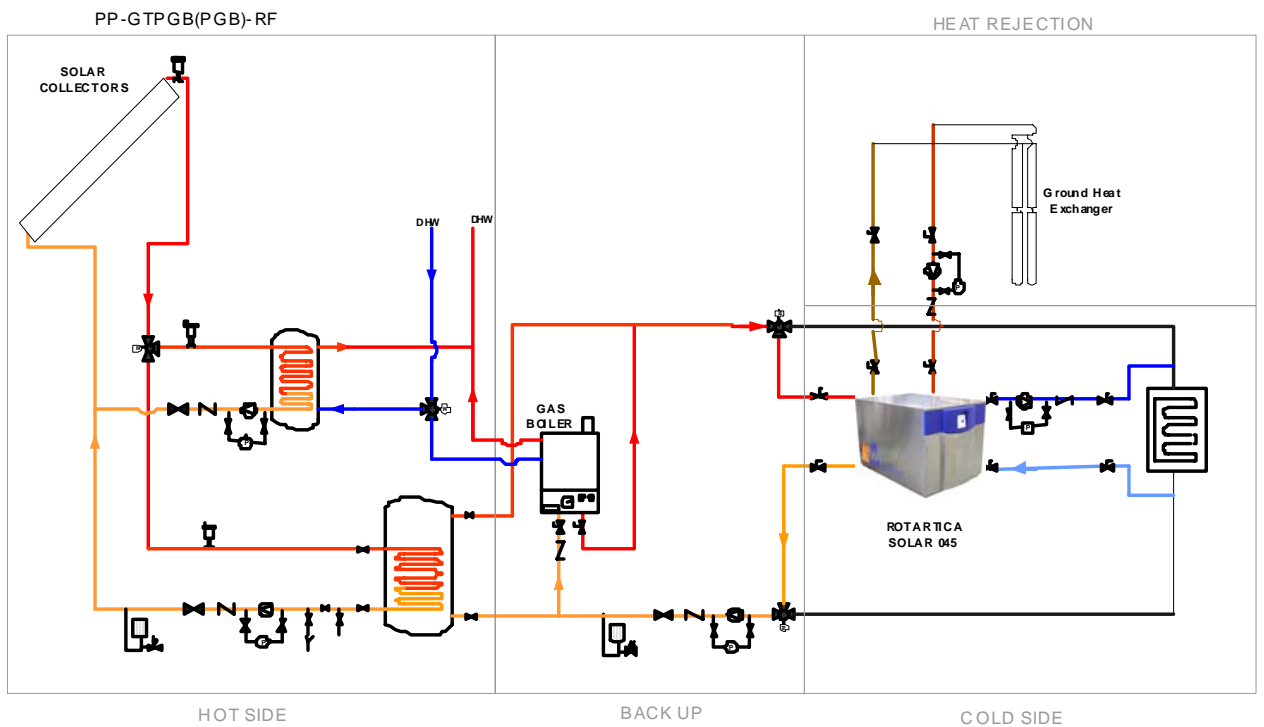

Figure 19: Solar heating and cooling system, Example 3 (source: Rotartica).

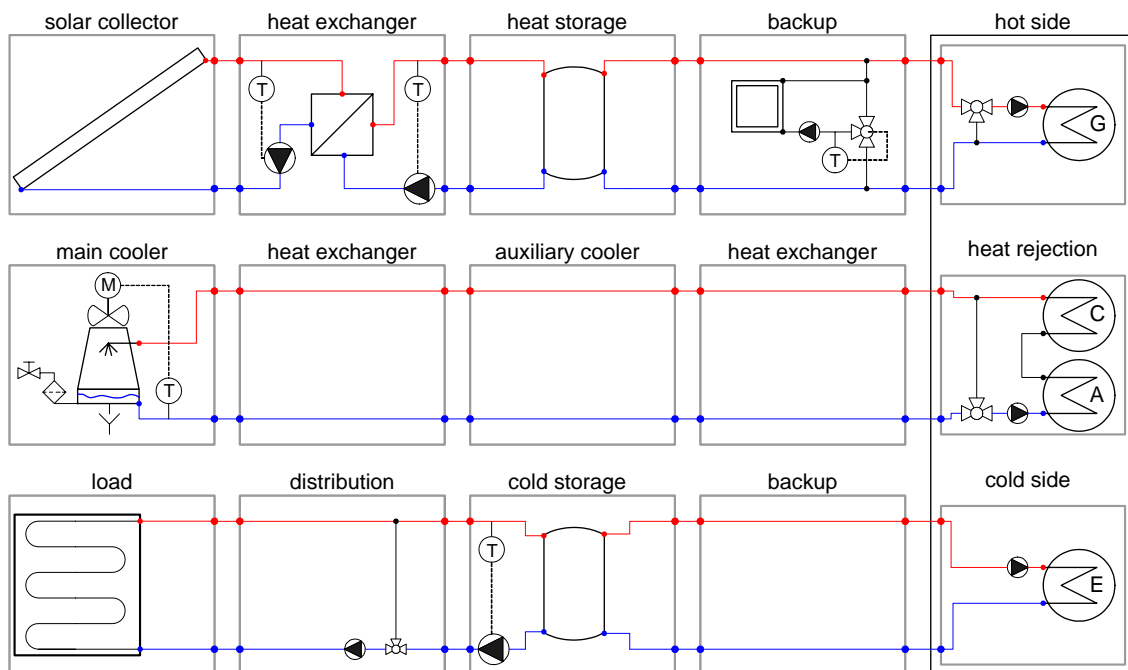
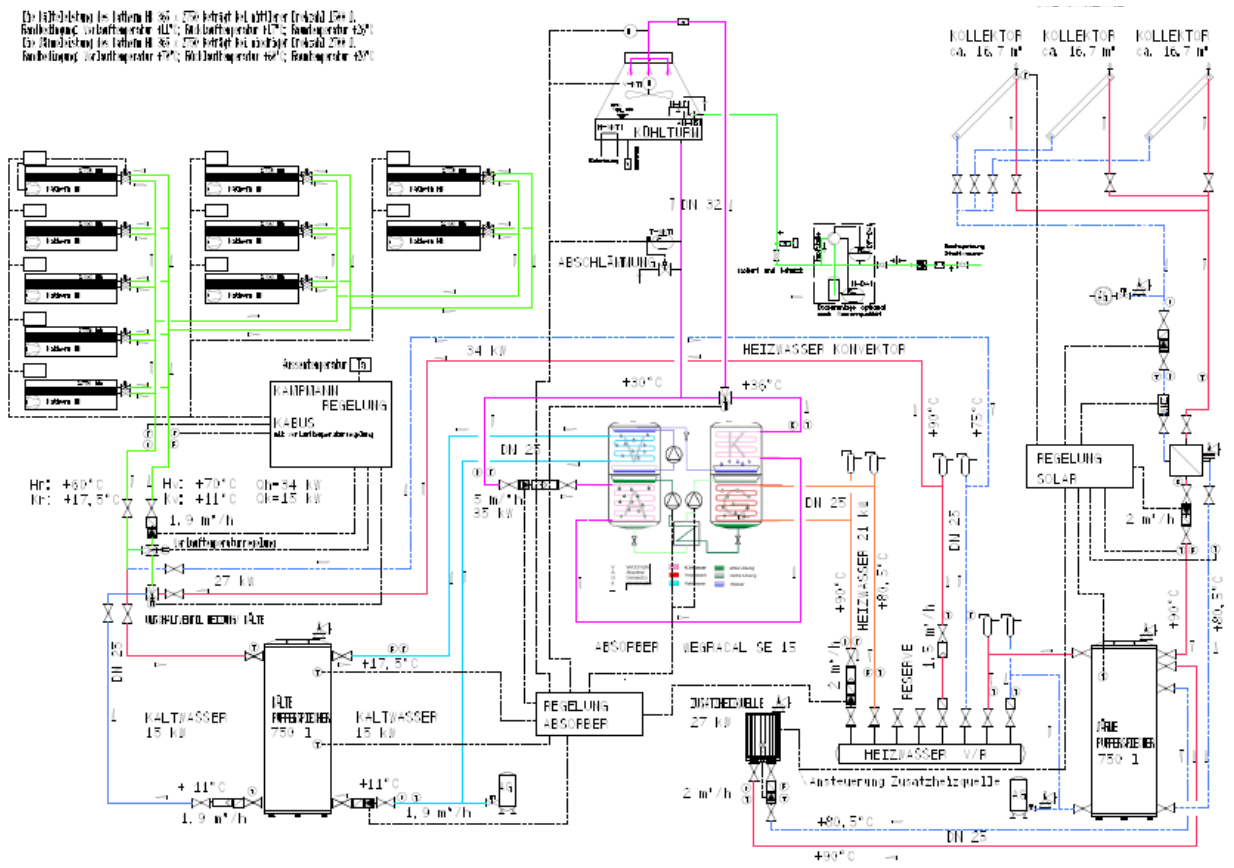

Figure 20: Solar heating and cooling system, Example 4: Pilot installation at company Festo, Esslingen, Germany (source: FH Offenburg).

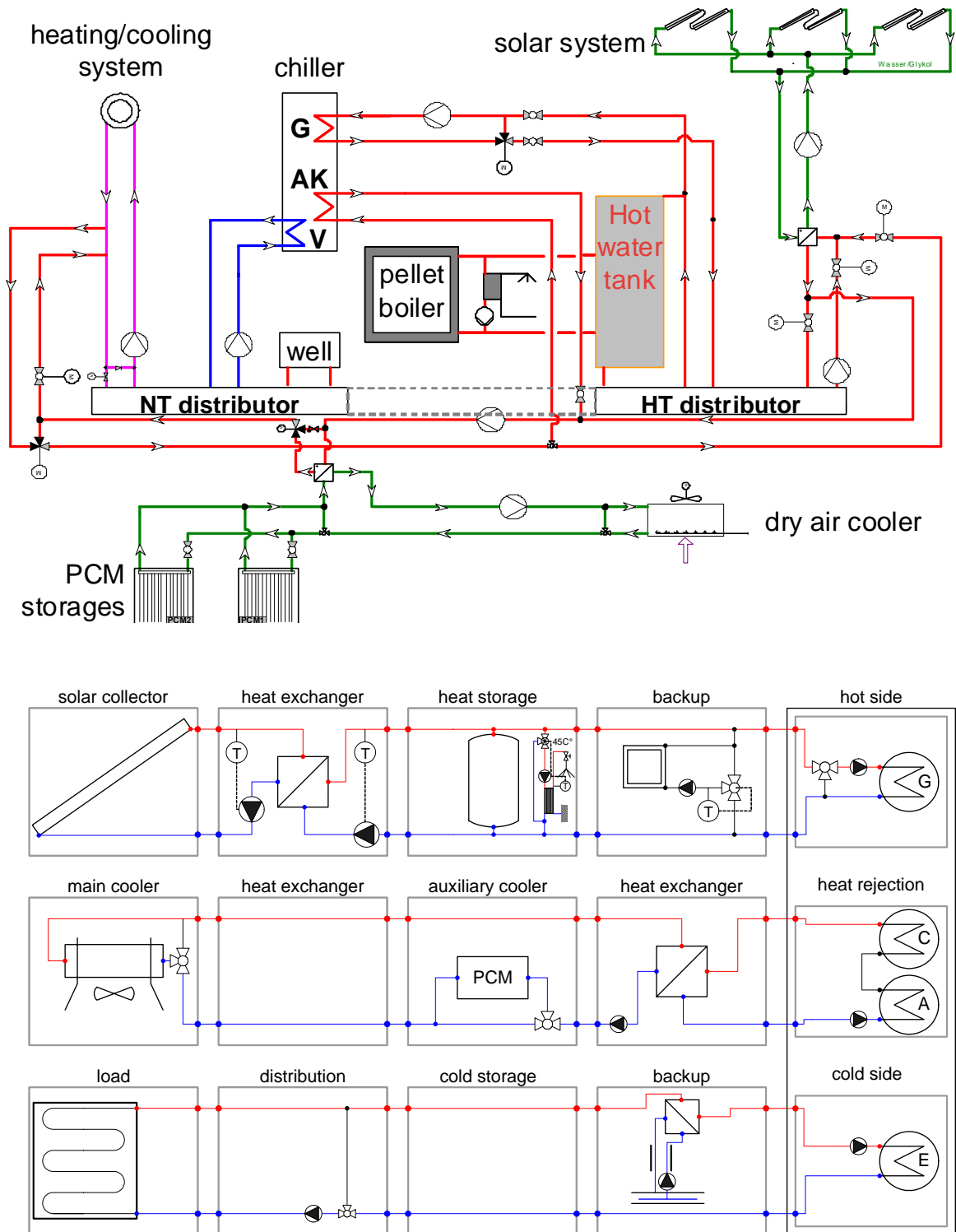

Figure 21: Solar heating and cooling system, Example 5: Pilot installation at ZAE Bayern, Garching, Germany (source: ZAE Bayern).